

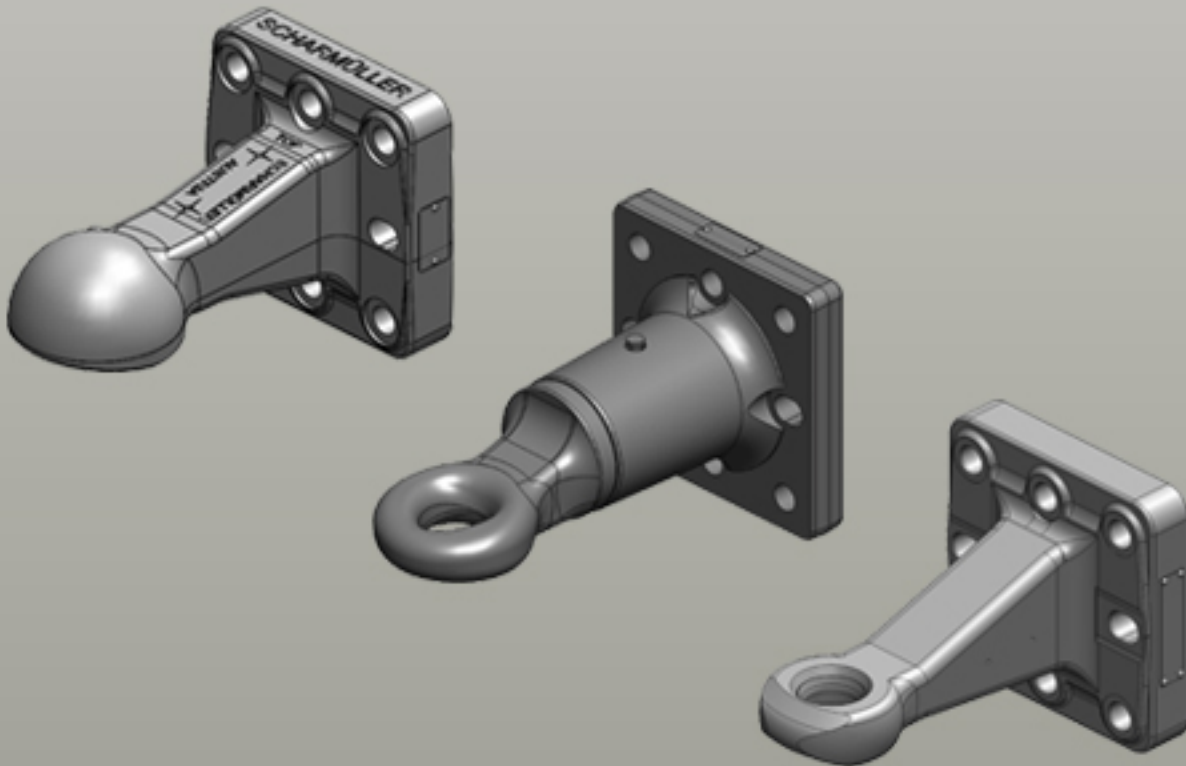









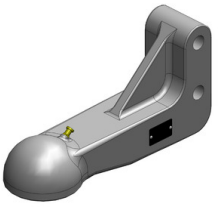

Towing Eyes | Angle



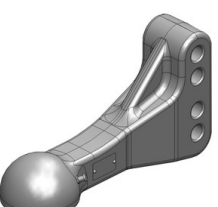

K80® Towing Eye Ball Coupling System

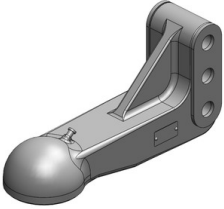

Towing Eyes | Angle

	<p>Art.Nr. 00.656.81.1-A02 Towing Eyes Angle K80® Towing Eye Ball Coupling System </p> <p>Alternative color </p> <p>00.656.81.1-A02 (Black)</p> <p>Technical Values*</p> <p>Hole Pattern Holes: 2 Working Length (mm): 300 Max. Permissible D-Value (kN): 57,2 Max. Permissible Vertical Load (kg): 1800 Hole Pattern/Hole Distance (mm): 100 Drilled Hole Ø (mm): 25 Shaft Height x Width: 192x90 Approval Status: ABG General Type Approval</p>
	<p>Art.Nr. 00.656.82.1-A02 Towing Eyes Angle K80® Towing Eye Ball Coupling System </p> <p>Alternative color </p> <p>00.656.82.1-A02 (Black)</p> <p>Technical Values*</p> <p>Hole Pattern Holes: 2 Working Length (mm): 300 Max. Permissible D-Value (kN): 57,2 Max. Permissible Vertical Load (kg): 1800 Hole Pattern/Hole Distance (mm): 90 Drilled Hole Ø (mm): 25 Shaft Height x Width: 192x90 Approval Status: ABG General Type Approval</p> <p>Geeignete Anhänger</p> <p>Claas: Quadrant: 2100, 2200;</p>
	<p>Art.Nr. 00.656.83.1-A02 Towing Eyes Angle K80® Towing Eye Ball Coupling System </p> <p>Alternative color </p> <p>00.656.83.1-A02 (Black)</p> <p>Technical Values*</p> <p>Hole Pattern Holes: 2 Working Length (mm): 300 Max. Permissible D-Value (kN): 57,2 Max. Permissible Vertical Load (kg): 1800 Hole Pattern/Hole Distance (mm): 90 Drilled Hole Ø (mm): 21 Shaft Height x Width: 192x90 Approval Status:</p>
	<p>Art.Nr. 00.656.84.1-A02 Towing Eyes Angle K80® Towing Eye Ball Coupling System </p> <p>Alternative color </p> <p>00.656.84.1-A02 (Black)</p> <p>Technical Values*</p> <p>Hole Pattern Holes: 2 Working Length (mm): 300 Max. Permissible D-Value (kN): 57,2 Max. Permissible Vertical Load (kg): 1800 Hole Pattern/Hole Distance (mm): 57 Drilled Hole Ø (mm): 27 Shaft Height x Width: 192x90 Approval Status:</p>
	<p>Art.Nr. 00.656.87.0-A23 Towing Eyes Angle K80® Towing Eye Ball Coupling System </p> <p>Alternative color </p> <p>00.656.87.0-A23 (Kioti-Grey) 00.656.87.0-A17 (JD-Green)</p> <p>Technical Values*</p> <p>Hole Pattern Holes: 4 Working Length (mm): 300 Max. Permissible D-Value (kN): 60,4 Max. Permissible Vertical Load (kg): 2500 Hole Pattern/Hole Distance (mm): 40 Drilled Hole Ø (mm): 26 Shaft Height x Width: 220x90 Approval Status: ABG General Type Approval</p> <p>Geeignete Anhänger</p> <p>Deutz: BM: 5712, 5912; GP: 81; Kuhn: LSB: 1270, 1290, 870, 890;</p>

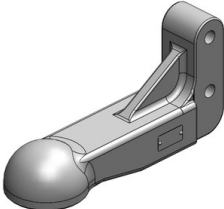
Towing Eyes | Angle

	Art.Nr. 00.656.90.0-A02 Towing Eyes Angle K80® Towing Eye Ball Coupling System
	Alternative color  00.656.90.0-A02 (Black)
	Technical Values* Hole Pattern Holes: 3 Working Length (mm): 300 Max. Permissible D-Value (kN): 57,2 Max. Permissible Vertical Load (kg): 1800 Hole Pattern/Hole Distance (mm): 58 Drilled Hole Ø (mm): 26 Shaft Height x Width: 192x102 Approval Status:
	Geeignete Anhänger Kuhn: Knight Slinger Pro-Twin: 8114, 8118, 8124, 8132, 8140, 8150, 8810;
	Art.Nr. 00.656.92.0-A02 Towing Eyes Angle K80® Towing Eye Ball Coupling System
	Alternative color  00.656.92.0-A02 (Black)
	Technical Values* Hole Pattern Holes: 2 Working Length (mm): 300 Max. Permissible D-Value (kN): 57,2 Max. Permissible Vertical Load (kg): 1800 Hole Pattern/Hole Distance (mm): 90 Drilled Hole Ø (mm): 21 Shaft Height x Width: 192x70 Approval Status:
	Geeignete Anhänger Claas: Quadrant: 1100, 1150, 1200; Grimme: GL: 34; GT: 170; GZ: 1700; SE: 75-20, 75-30, 75-40;