

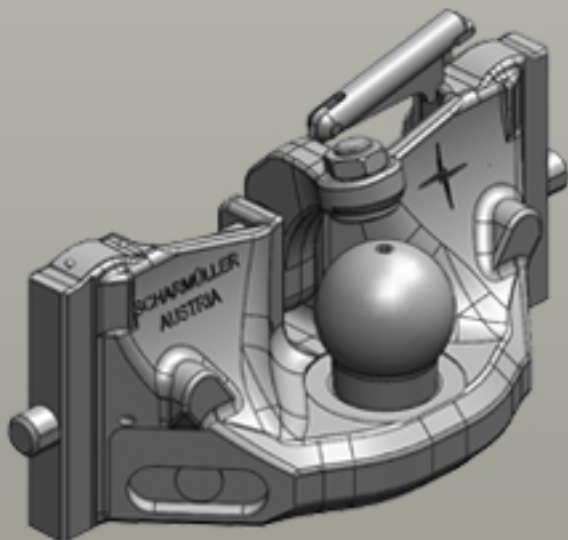

Inserts for Ladder Hitches Assembly Dimension Cramer (293/22/30)



Inserts for Ladder Hitches

	<p>Art.Nr. 03.6293.22-A02 Inserts for Ladder Hitches Coupling Inserts Draw-Pin (Pitonfix) Assembly Dimension Cramer (293/22/30)</p> <p>Alternative color </p> <p>03.6293.22-A02 (Black)</p> <p>Technical Values*</p> <p>Thread: M20 Working Length (mm): 155 Adapter Plate Height (mm): 160 Locking: Draw Pin (Pitonfix) Manual Max. Permissible D-Value (kN): 83,9 Max. Permissible Vertical Load (kg): 2000 • Height Adjustable with Grabhandle</p>
	<p>Art.Nr. 03.6293.42-A02 Inserts for Ladder Hitches Coupling Inserts K80® Ball Coupling System Assembly Dimension Cramer (293/22/30)</p> <p>Alternative color </p> <p>03.6293.42-A02 (Black)</p> <p>Technical Values*</p> <p>Thread: M20 Working Length (mm): 155 Adapter Plate Height (mm): 160 Locking: K80® Manual Max. Permissible D-Value (kN): 83,9 Max. Permissible Vertical Load (kg): 2000 • Height Adjustable with Grabhandle</p>
	<p>Art.Nr. 03.7293.02-A02 Inserts for Ladder Hitches Coupling Inserts ISO 50 (Car) Assembly Dimension Cramer (293/22/30)</p> <p>Alternative color </p> <p>03.7293.02-A02 (Black)</p> <p>Technical Values*</p> <p>Thread: M20 Working Length (mm): 125 Adapter Plate Height (mm): 120 Max. Permissible D-Value (kN): 17 Max. Permissible Vertical Load (kg): 200 • Height Adjustable with Grabhandle</p>
	<p>Art.Nr. 03.7293.52-A02 Inserts for Ladder Hitches Adapter Plates Assembly Dimension Cramer (293/22/30)</p> <p>Alternative color </p> <p>03.7293.52-A02 (Black)</p> <p>Technical Values*</p> <p>Flange Hole Pattern (mm): 140x80 Thread: M20 Hole Pattern Holes: 4 Adapter Plate Height (mm): 160 Max. Permissible D-Value (kN): 83,9 Max. Permissible Vertical Load (kg): 2000 • Height Adjustable with Grabhandle</p>